

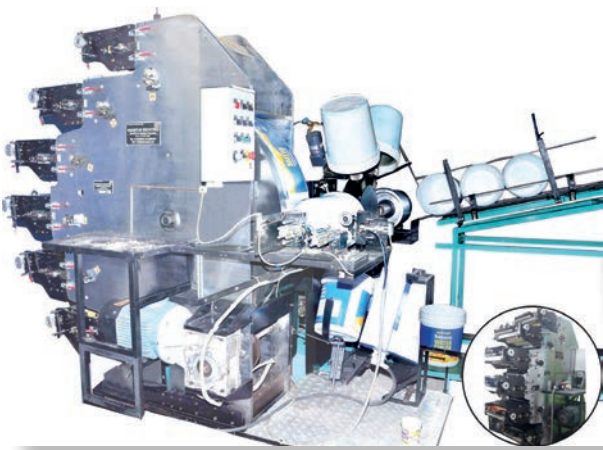

Pail Printing Systems

6-Color Dry Offset GCP Series Pail Printer

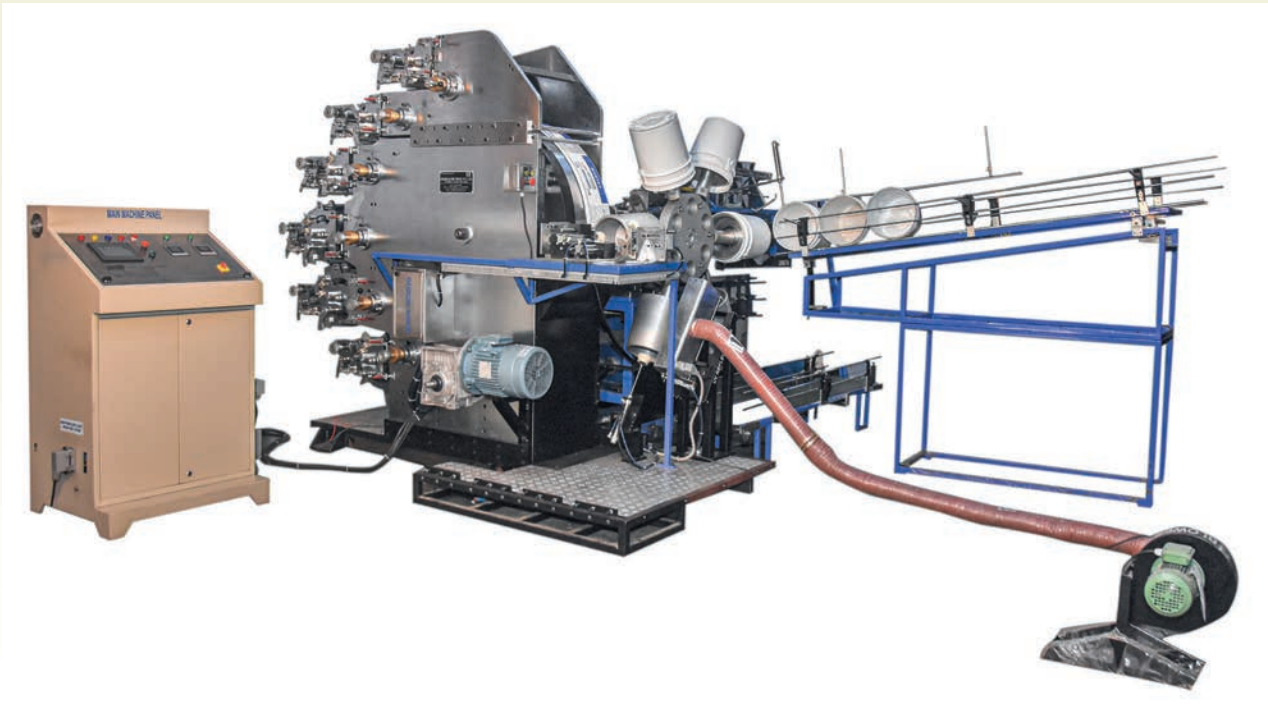
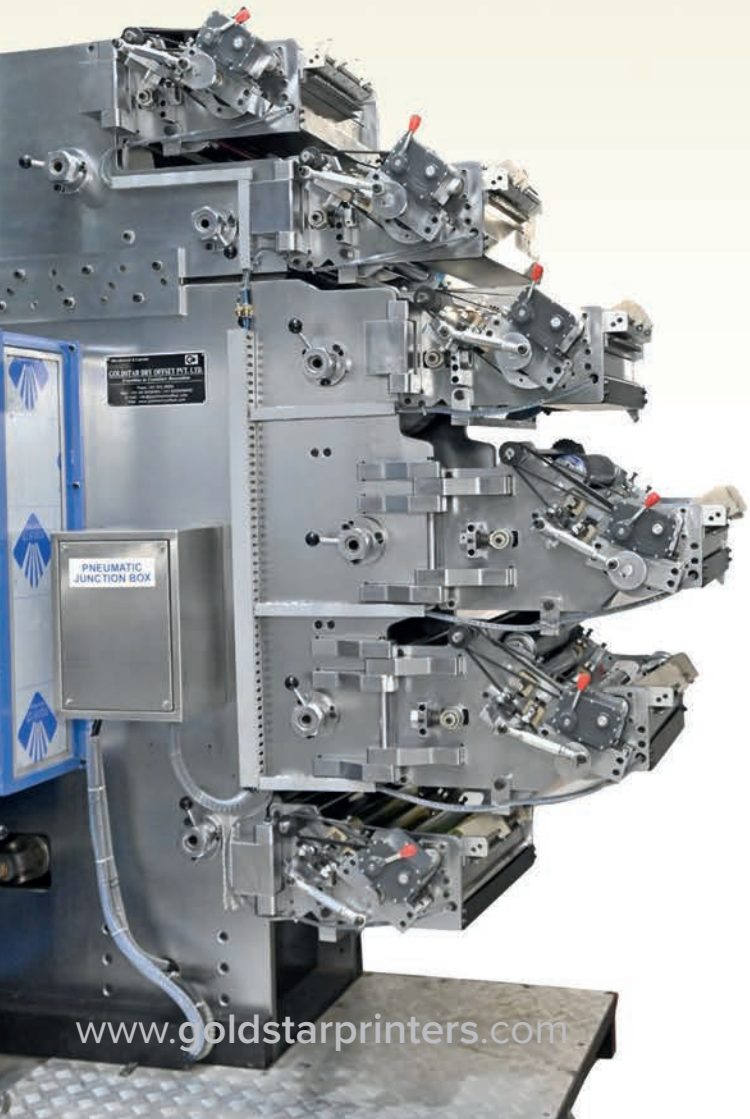

6-Color Dry Offset GCP Series Pail Printer



Our GCP Series Pail Bucket Printer is an advanced **6 color printing** solution that guarantees high printing accuracy.

This offset pail printing machine is suitable for **wide mouth conical and cylindrical** containers.

The positive timing throughout the machine ensures that each container is printed accurately.

The GCP Series Pail Bucket Printer can print about **800 impression per hour** with a suitability to **print from 1 litre to 20 litre** pail sizes.

The add-on features include:

- Offline registration, which allows for accurate printing registration even when the machine is in running condition.
- **PLC based ink transfer system** that ensures precise ink transfer and reduces the risk of ink wastage.
- Maintenance-free ink distribution system eliminates the need for regular maintenance, making the machine easy to use and maintain.
- Multi-speed gearbox with neutral position provides increased flexibility and control over the printing process, allowing users to adjust the speed and position of the machine as needed.

Features

- Zeromax drive for auto ink control
- Auto loading
- Flame treatment with auto ignition
- 360 degree printing with precise registration & automatic orientation
- Instantaneous UV drying
- Auto ejection with exit conveyor
- Lower ink consumption
- Less floor space
- Anti-backlash plate cylinder helical gear
- Micrometer lateral and radial plate cylinder adjustment
- Positive timing throughout machine

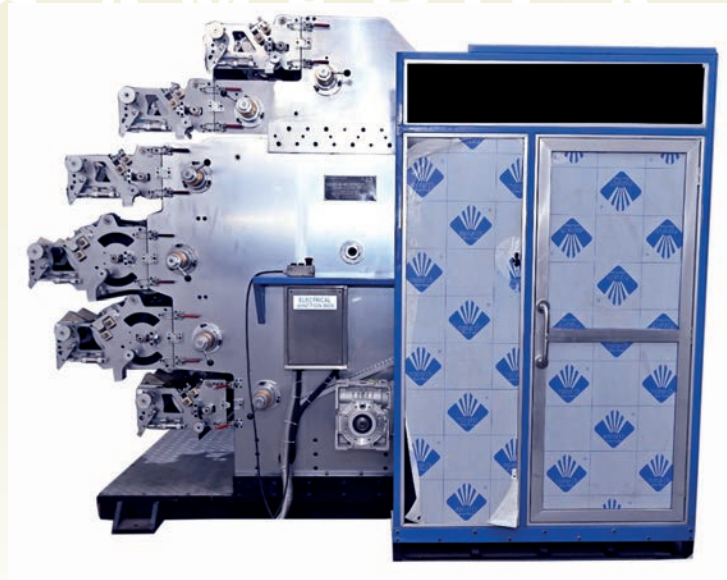

Add-on Features

- Offline registration
- PLC based ink transfer system
- Maintenance free ink distribution system
- Multi speed gearbox with neutral position

Optional

- Magnetic plate cylinder

TECHNICAL DETAILS

Min. - Max. Diameter	110mm x 350mm
Min. - Max. Height	120mm x 400mm
Max. Print Area	900mm (L) x 275mm (H)
Electric Motor Drive	AC gear motor 7.5 HP, 3 Phase, 50Hzs with inverter for fine speed control
Pneumatic Pressure	@ 8-10 kg/cm ²
Air Consumption	@ 12m ³ /hr
Max. Impression	@ 700-800 per hour (20 ltr. bucket)
Total Power Consumption	14 kilowatts
Total Machine Weight	8,000 kg
Machine Dimensions	5,500mm (L) x 3,000mm (W) x 2,500mm (H) (including loading & unloading conveyor)

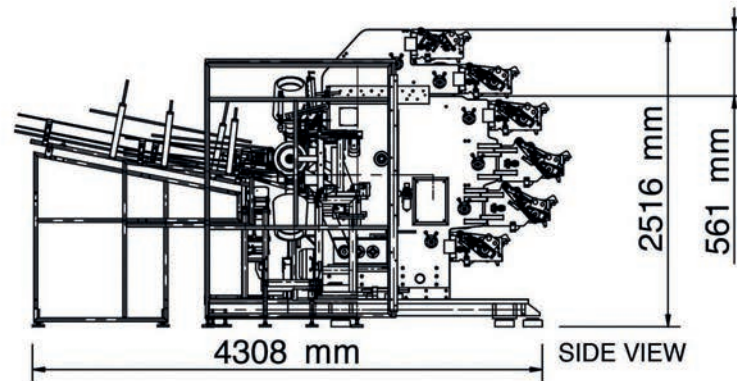
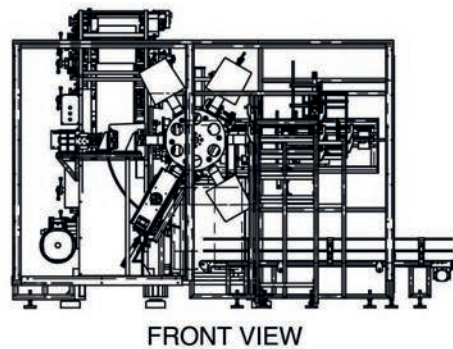
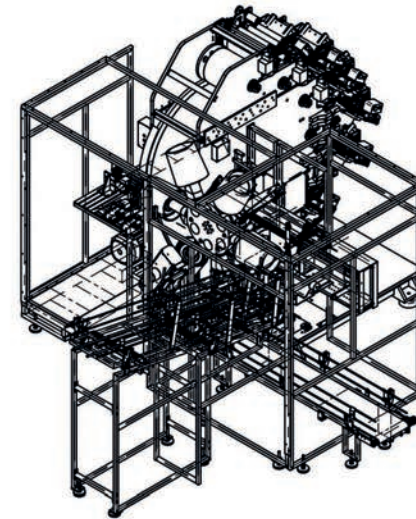
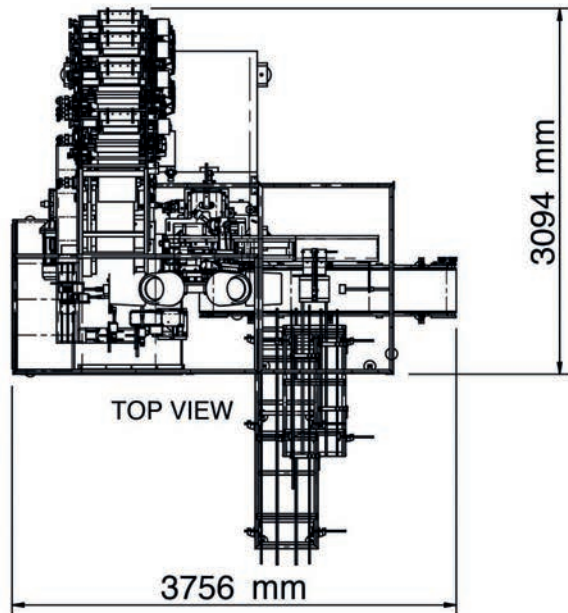

Dimensions are shown in inches

GOLDSTAR AMERICA

1903 Case Parkway, Twinsburg,
44807 OH, USA

Tel: +1 330 405 1581
Email: sales@goldstarprinters.com

www.goldstarprinters.com